

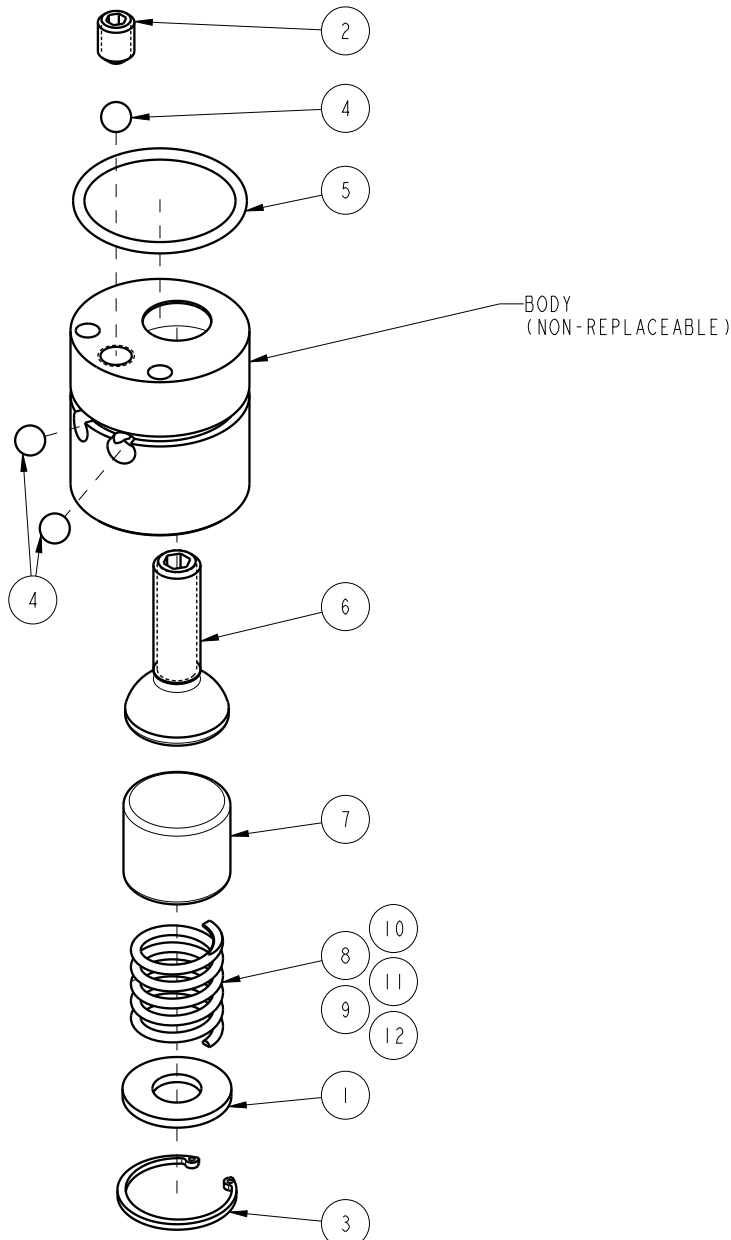

NO	QTY	PART NO	DESCRIPTION	2				
				66-0915-01 LIGHT	66-0915-02 MEDIUM	66-0915-03 HEAVY	66-0915-04 XHVV	66-0915-05 XXHVV
1	1	21430041	WASHER					
2	1	21440003	SHSS, FLAT POINT, SELF-LOCKING					
3	1	23050029	RETAINING RING, BASIC INTERNAL					
4	3	23600014	BALL, STEEL, ALLOY, .156					
5	1	39051122	O-RING, (20mm x 1.5)					
6	1	86615002	PIVOT, THREADED, PRP, 15					
7	1	86615003	CUP, SPRING, PRP, 15					
8	1	23350108	SPRING, COMPRESSION	X				
9	1	23350109	SPRING, COMPRESSION		X			
10	1	23350110	SPRING, COMPRESSION			X		
11	1	23350118	SPRING, COMPRESSION				X	
12	1	23350119	SPRING, COMPRESSION					X



<b>PARTS LIST</b>	 <b>VEKTEK</b> VEKTEK, INC. 1334 E. SIXTH AVE. P.O. BOX 625 EMPORIA, KS. 66801 U.S.A.
	<b>PARTS LIST, DURA PIN, 15</b> *****
ASSEMBLIES AFFECTED 66-0915-01, 66-0915-02 66-0915-03, 66-0915-04 66-0915-05	SIZE A
PL6602	REV C

C	4734	RELEASE	RLK	8/11/22
REV	IN ACCORDANCE WITH ECN	EFFECTIVE DATE	REVISED BY	DATE
DRW BY: D. BEDFORD	<b>DRAWING STATUS: Released</b>			
DATE: 07/17/14	PRODUCTION APPROVED FOR RELEASED STATUS ONLY			